

JDN ULTRA-LOW MONORAIL HOISTS



**Carrying capacities:
4 t up to 100 t
Air pressure: 6 bar**

Where loads have to be lifted and transported in extremely reduced spaces the **JDN Ultra-Low Monorail Hoists** provide the ideal solution. For example the Ultra-Low Monorail Hoist with a load capacity of 6 t has a headroom of only 230 mm.

Standard Features

- Ideally suited for working in hazardous areas (explosion risk)
- Insensitive to humidity, dust and temperatures from -20°C up to +70°C
- Extremely low headroom
- Low air consumption
- Available with increased spark protection



UH 100

Technical Data

Type		UH 4	UH 6	UH 8	UH 12	UH 16
Carrying capacity	mt	4	6	8	12	16
Number of chain strands		2	2	4	4	4
Motor output	kW	2.5	2.5	2.5	2.5	2.5
Air pressure	PSI bar	85 6	85 6	85 6	85 6	85 6
Lifting speed at full load	ft/min m/min	9.84 3.0	6.56 2.0	4.59 1.4	2.95 0.9	2.13 0.65
Lifting speed without load	ft/min m/min	19.69 6.0	14.76 4.5	9.51 2.9	7.22 2.2	3.94 1.2
Lowering speed at full load	ft/min m/min	24.61 7.5	17.06 5.2	11.81 3.6	8.20 2.5	4.92 1.5
Air consumption lifting – full load	cfm m ³ /min	141.26 4.0	141.26 4.0	141.26 4.0	141.26 4.0	141.26 4.0
Air consumption lowering – full load	cfm m ³ /min	194.23 5.5	194.23 5.5	194.23 5.5	194.23 5.5	194.23 5.5
Air connection		G 3/4	G 3/4	G 3/4	G 3/4	G 3/4
Hose dimension (Ø inside)	inch mm	0.75 19	0.75 19	0.75 19	0.75 19	0.75 19
Weight with standard lift	lbs kg	1014.13 460	1036.17 470	1190.50 540	1212.54 550	1234.60 560
Chain dimension	mm	13 x 36	13 x 36	13 x 36	13 x 36	13 x 36
Weight of 1m chain	lbs kg	8.38 3.8	8.38 3.8	8.38 3.8	8.38 3.8	8.38 3.8
Standard lift	ft m	10 3	10 3	10 3	10 3	10 3
Length of control at standard lift	ft m	6.5 2	6.5 2	6.5 2	6.5 2	6.5 2
Noise level at full load ¹ – lifting	dB(A)	78	78	78	78	78
Noise level at full load ¹ – lowering	dB(A)	80	80	80	80	80

¹Measured at 1m distance acc. to DIN 45635 part 20
Group mechanism: M3 (1 Bm)
Technical data for higher capacities on request.



J.D. NEUHAUS
powered by air!

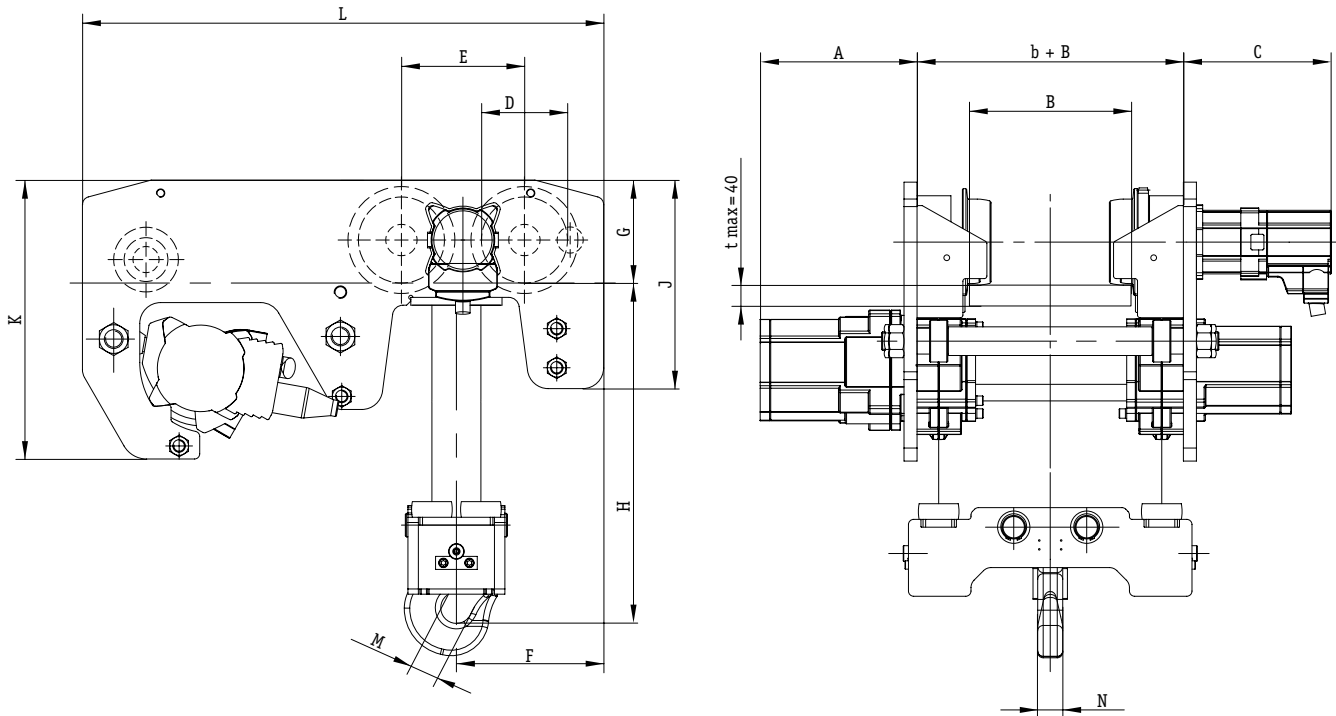

Dimensions

Type		UH 4	UH 6	UH 8	UH 12	UH 16
A	inch	7.68	12.01	7.68	12.01	12.01
	mm	195	305	195	305	305
B	inch	7.87	7.87	7.87	7.87	7.87
	mm	200	200	200	200	200
C	inch	11.16	11.16	11.16	11.16	11.16
	mm	284	284	284	284	284
D	inch	6.50	6.50	6.50	6.50	6.50
	mm	165	165	165	165	165
E	inch	9.29	9.29	9.29	9.29	9.29
	mm	236	236	236	236	236
F	inch	12.99	12.99	11.14	11.14	11.14
	mm	330	330	283	283	283
G	inch	7.78	7.78	7.78	7.78	7.78
	mm	197.5	197.5	197.5	197.5	197.5
H min. 150 ≤ b ≤ 310	inch	9.06	9.06	-	-	-
	mm	230	230	-	-	-
H min. 150 ≤ b ≤ 230	inch	-	-	11.61	11.61	13.15
	mm	-	-	295	295	334
H min. 230 ≤ b ≤ 310	inch	-	-	10.87	10.87	12.40
	mm	-	-	276	276	315
J	inch	15.75	15.75	15.75	15.75	15.75
	mm	400	400	400	400	400
K	inch	21.06	21.06	21.06	21.06	21.06
	mm	535	535	535	535	535
L	inch	39.37	39.37	39.37	39.37	39.37
	mm	1000	1000	1000	1000	1000
M	inch	1.57	1.57	1.73	1.73	2.09
	mm	40	40	44	44	53
N	inch	2.01	2.01	2.60	2.60	3.23
	mm	51	51	66	66	82

Dimensions for higher capacities on request.